

315 SERIES

SYNCHRONOUS ALTERNATORS

4 POLE 50/60 Hz - THREE PHASE

GENPOWER®

ALTERNATOR

General Information

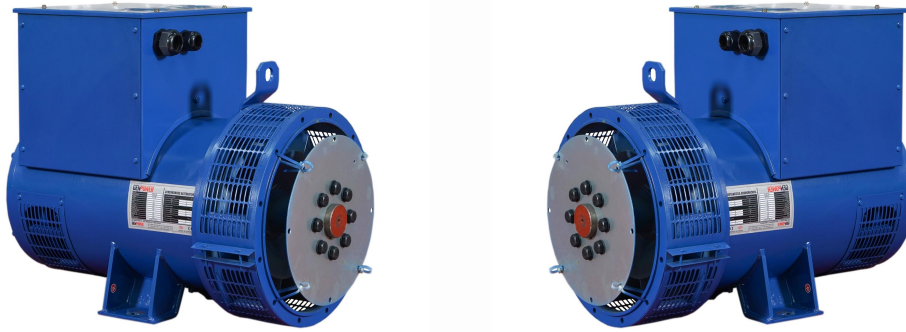

STANDARD SPECIFICATIONS

General Specifications

Genpower, is an independent and internationally recognized power producer, specializing exclusively on manufacturing of synchronous alternators.

Genpower focuses its corporate mission on original and self-made designs; innovative solutions and provide long-term and sustainable development.

Turkish and foreign technical teams are always working with their knowhow and experience in order to meet universal demands and projects and to have a continuous increase in the performance, total lifespan and overall reliability of the products. Genpower continues the R&D studies with universities both in Turkey and in other countries who have comprehensive knowledge on its products.

Genpower synchronous alternators are proven to endure the harshest environmental applications. They proved to be one of the most reliable and preferred alternator brands all over the world with their brushless and self-exciting system, electronic voltage regulator (AVR), stable wave form, low harmonic distortion and high efficiency.

In case of a demand, Genpower can also produce direct current (DC) alternators, 50-60 Hz low voltage (LV) alternators, medium voltage alternators, high voltage alternators; alternators for light towers, welding alternators, IP44 and PI54 class alternators for marine applications, variable speed alternators for telecom projects and cranes; high frequency alternators for ground power units, radars, planes and helicopters.

Product Application

Genpower alternators are mainly used in the application of diesel, gasoline and gas generator groups. They are also able to operate with steam or hydraulic turbines. They operate in all configurations of emergency generator groups, power plants or continuous power sources.

- Industrial and commercial complex.
- Telecommunication and cell-phone towers, radio and television transmitters
- Defense industry and military projects.
- Construction sites, mining, stone crushers and mixing plants, light towers
- Agriculture and irrigation; cattle and chicken farms
- Hotels and hospitals, lofts, care centers, clinics
- Offices, shops, factories, workshops, buildings, sports complexes, stores, malls, banks, gas stations
- Rental companies, mobile service vehicles, mobile hospitals, and other mobile facilities
- Airports, initial starting of the air vehicles, ground services

Standards

Genpower synchronous alternators are designed and manufactured in compliance with TSE 60034-1; IEC 60034-22; GB755; BS4999-5000; NEMA MG 1.22 CE marking approved and are also accredited with ISO 9001: 2008 and ISO 14001:2004.

TECHNICAL SPECIFICATIONS



ISO 9001:2008
OHSAS 18001:2007
ISO 14001:2004



General Information

Terminal & Terminal Box

Standard generators are 3-phase reconnect able with 12 ends brought out to the terminals, which are mounted on a cover at the non-drive end of the generator. A sheet steel terminal box contains the AVR and provides ample space for the customers' wiring and gland arrangements. It has removable panels for easy access.

Insulation / Impregnation (VPI)

The insulation system is class H. All winding components are impregnated in an unsaturated polyester resin of 200 class temperature. The impregnation provides much needed rigidity and protection against the harsh environment, typical for the generators applications. Genpower alternators are delivered with Genpower insulation system. This insulation system is based on the "Vacuum Pressure Impregnation" (VPI) system which was developed in cooperation with the most renowned suppliers of insulation material all over the world. Using special epoxy based resin; this insulation system ensures perfect winding insulation of the alternators and does not emit harmful gases into the environment.

Dynamic Balancing

The rotating (Main rotor, exciter rotor, diode group, fan) parts are dynamically balanced with greater precision than that required by the Standard TSE EN IEC 60034-14 and ISO2372, ensuring minimum levels of residual unbalance.

Waveforms / Radio Interference

The alternators are designed to give an excellent output waveform. The total harmonic content of line voltage waveform on no load is less than 5% as per limits specified by TSE / IEC Standards.

The Alternators are having negligible Radio Frequency Interference and meets the general limits permitted by VDE 0875 (N). TIF value is <50 and THF value is <2%.

Transient Ratings

Transient voltage drop due to application of full load at 0.8 power factor is less than 18% output voltage recovers to within 3% of the rated value in less than 0.3 seconds.

Continuous Duty / S1 – Ambient Temperature / 40°C

The alternator operates at rated power for an unlimited time with the possibility of overload up to 10% for 1 hour every 12 hours, without damage to its insulation system. The S1, also called continuous or prime duty is applied mainly where there is not another power source available, such as; groups for rental groups for irrigation, refrigeration and application for peak hours. For continuous duty, it is accepted a temperature raise in the windings of up to 125°C.

Standby Duty – Ambient Temperature / 40°C

The generator group operates as energy backup with variable loads in emergency situations in places supplied by the grid / utility company or another main power source. In this kind of duty, the machine does not accept overloads and operates with variable loads up to the rated power of the stand-by duty (40°C). A raise in the winding temperature of up to 150°C is accepted (as per Standard of TSE 60034 / IEC 60034), However if that happens the useful life of the alternator reduces 2 to 6 times. The use of the alternator in stand-by duty is limited to 500 hours a year.

Operating Conditions

When choosing an alternator, "ALTITUDE", "AMBIENT TEMPERATURE" and "POWER FACTOR" should be taken into consideration. Power drops should be calculated with the help of the table below and power determination should be done accordingly.

General Information

Altitude

The rated power refers to installations up to 1000 meter above sea level. For applications over this altitude, the following power correction factor must be applied.

Altitude (m)	<1000	<1500	<2000	<2500	<3000
K Factor	1	0.96	0.93	0.90	0.86

Power Factor (Cos Q)

The nominal power factor is 0.8 lagging. For application with power factor value different from 0.8, the following correction factor must be applied.

Power Factor (CosQ)	0.80	0.70	0.60	0.50	0.30	0
K Factor	1	0.93	0.88	0.84	0.82	0.80

Temperature Rise

Temperature rise is the increase in temperature above ambient temperature 40°C ratings.

Temperature Rise	Temperature °C
B	80°C
F	105°C
H	125°C

Generator Set Ratings

The tables below summarize the definitions accordance to TSE 8528-1 / ISO 8528-1 for the generator set and a combination of TSE 8528-3 / ISO 8528-3 and TSE 60034-1 / IEC 60034-1 for the alternator.

Genset Rating TSE 8528-1	Emergency Standby Power (ESP)	Limited Time Prime Power (LTP)	Prime Rated Power (PRP)	Continuous Operating Power (COP)
Load Type	Variable	Constant	Variable	Constant
Annual Operating Hors	200	500	Unlimited	Unlimited
Average Load	70%	100%	70%	100%
Overload	No	No	10% 1 Hour in every 12	No
Alternator Rating	Standby	Standby	Continuous	Continuous
Duty Cycle	S10	S10	S1	S1
Alternator Ratings	Standby 150/40°C	Standby 150/40°C	Class H 125/40°	Class H 125/40°
	Standby 163/27°C	Standby 163/27°C	Class F 105/40°C	Class F 105/40°C

Ambient Temperature

The rated powers refer to installation with ambient temperature of 40°C. For applications different from 40°C, the following power correction factor must be applied.

Ambient Temperature	30°C	35°C	40°C	45°C	50°C	55°C
K Factor	1.04	1.02	1	0.96	0.93	0.90

Thermal Insulation Class

Insulation class governs the maximum permissible temperature an alternator can operate without damaging the insulation system.

Insulation Class	Maximum Permissible Temperature
F	155°C
H	180°C

Stand-by application allows windings to run hotter than the class H temperature rise limit, therefore for an ambient of;

40°C Temperature Rise : 150°C

27°C Temperature Rise : 163°C

400V – 50 Hz

Alternator Technical Data – 50Hz

4 POLE 1500 RPM 50 Hz

TYPICAL DATA

Insulation class	H	Control system	Self excited
Winding pitch	2/3 - (N° 6)	A.V.R. model (*)	Standard SX440
Wires	12	Voltage regulation	± 1.0 %
Drip proof	IP 23	Sustained short-circuit current	300% (3 IN) : 10s
Altitude	≤ 1000 m	Total harmonic (**) TGH / THC	< 4 %
Overspeed	2250 min-1	Wave form: NEMA = TIF - (*)	< 50
Air flow	0.8 m³/sec.	Wave form: I.E.C. = THF - (*)	< 2 %
Bearing drive	-	Bearing non-drive	6314 - 2RZ

(*) Total harmonic content line to line, at no load or full rated linear and balanced load

50 Hz kVA / kW – Power Factor (CosQ) = 0,8

Duty/Ambient C°	Continuous / 40°C			Stand-by / 27°C		
	H / 125° K			H / 163° K		
Class/C° rise						
Series Star (V)	380/220	400/231	415/240	380/220	400/231	415/240
Parallel Star (V)	190/110	200/115	208/120	190/110	200/115	208/120
Series Delta (V)	220	230	240	220	230	240
GNP 315 S	kVA	373	373	380	410	418
	kW	298	298	304	328	334
GNP 315 M	kVA	409	409	417	450	459
	kW	327	327	334	360	367
GNP 315 MX	kVA	432	432	441	475	485
	kW	346	346	353	380	388
GNP 315 MXA	kVA	468	468	477	515	525
	kW	374	374	382	412	420
GNP 315 L	kVA	514	514	524	565	576
	kW	411	411	419	452	461

REACTANCES (%) – TIME CONSTANTS (ms) : CLASS: H / 400 V

	400 V	315 S	315 M	315 MX	315 MXA	315 L
VOLTAGE SERIAL STAR						
DIR. AXIS SYNCHRONOUS	Xd	2,85	2,71	2,45	2,41	2,4
DIR. AXIS TRANSIENT	X'd	0,18	0,18	0,16	0,154	0,152
DIR. AXIS SUBTRANSIENT	X''d	0,13	0,13	0,12	0,115	0,11
QUAD. AXIS REACTANCE	Xq	2,4	2,33	2,15	2,12	2,1
QUAD. AXIS SUBTRANSIENT	X''q	0,36	0,32	0,28	0,27	0,25
LEAKAGE REACTANCE	XL	0,06	0,06	0,05	0,05	0,05
NEGATIVE SEQUENCE	X2	0,24	0,22	0,21	0,2	0,2
ZERO SEQUENCE	X0	0,09	0,09	0,085	0,08	0,08

OTHER DATA – CLASS H / 400 V

T'd TRANSIENT TIME CONST.	0,08 s	0,08 s	0,08 s	0,08 s	0,08 s
T''d SUB-TRANSTIME CONST.	0,019 s	0,019 s	0,019 s	0,019 s	0,019 s
T'do O.C. FIELD TIME CONST.	1,7 s	1,7 s	1,7 s	1,7 s	1,7 s
Ta ARMATURE TIME CONST.	0,018 s	0,018 s	0,018 s	0,018 s	0,018 s
SHORT CIRCUIT RATIO	1/Xd	1/Xd	1/Xd	1/Xd	1/Xd

315 SERIES

SYNCHRONOUS ALTERNATORS

4 POLE 50/60 Hz - THREE PHASE

GENPOWER[®]

ALTERNATOR

400V – 50 Hz

STANDARD SPECIFICATIONS

3 Phase / 400V / 50 Hz Efficiency Curves & Percent Transient Voltage Dip & Alternator Windings

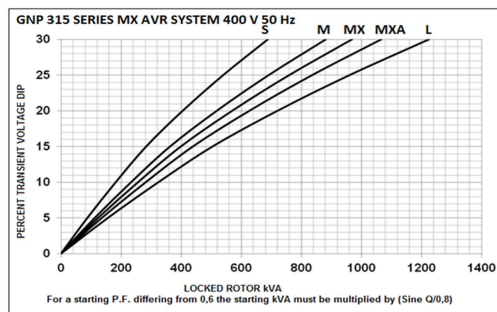
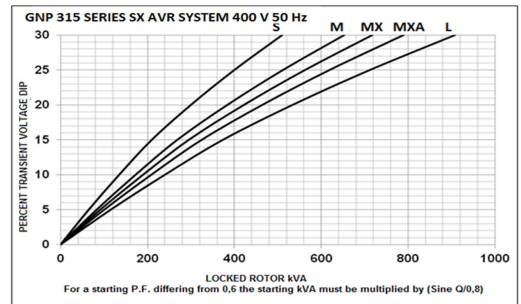
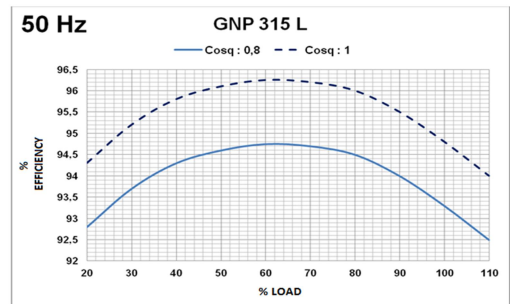
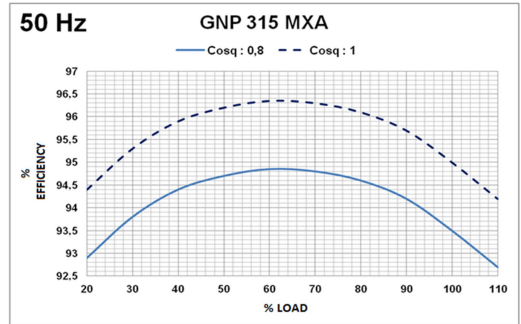
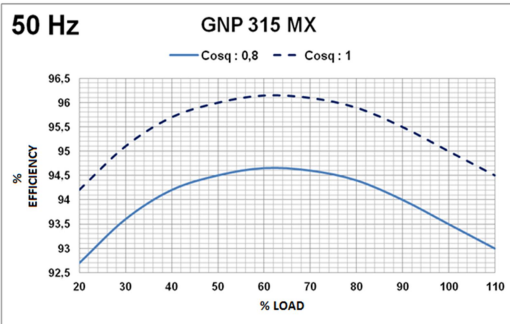
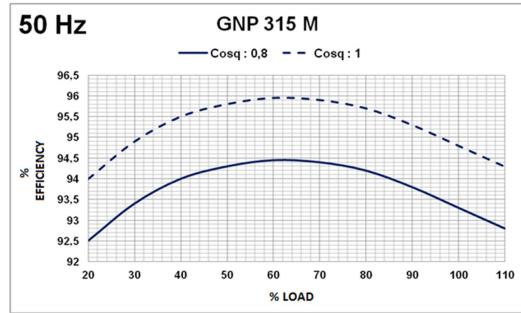
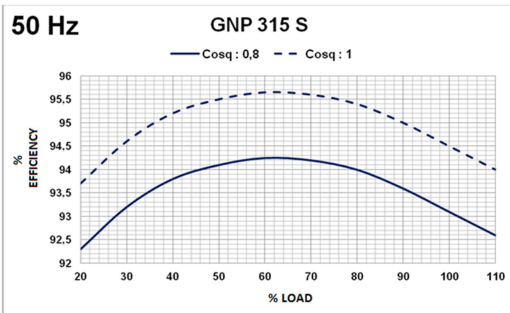

ALTERNATOR WINDINGS						
4 Pole 50 Hz - 1500 R.P.M						
Phase	3	3	3	3	3	1
Connections						
Number of Leads	6	6	12	12	12	12
Standard Winding	380 - 400 - 415V	220 - 240V	380 - 400 - 415V	220 - 240V	190 - 208V	220 - 240V

TECHNICAL SPECIFICATIONS

High quality 100% copper wires are used in the rotors, stators and excitation wirings of GENPOWER alternators. All metal sheets used in the production are siliceous metals. Therefore, GNP alternators have higher efficiency compared to exemplary products.

480V – 60 Hz

Alternator Technical Data – 60Hz

4 POLE 1800 RPM 60 Hz

TYPICAL DATA

Insulation class	H	Control system	Self excited
Winding pitch	2/3 - (N° 6)	A.V.R. model	Standard SX440
Wires	12	Voltage regulation	± 1.0 %
Drip proof	IP 23	Sustained short-circuit current	300% (3 IN) : 10s
Altitude	≤ 1000 m	Total harmonic (*) TGH / THC	< 5 %
Overspeed	2250 min-1	Wave form: NEMA = TIF - (*)	< 50
Air flow	0.99 m³/sec.	Wave form: I.E.C. = THF - (*)	< 2 %
Bearing drive	-	Bearing non-drive	6314- 2RZ

(*) Total harmonic content line to line, at no load or full rated linear and balanced load

60 Hz kVA / kW – Power Factor (CosQ) = 0,8

Duty/Ambient C°	Continuous / 40°C			Stand-by / 27°C			
	H / 125° K			H / 163° K			
Class/C° rise							
Series Star (V)	416/240	440/254	480/277	416/240	440/254	480/277	
Parallel Star (V)	208/120	220/127	240/138	208/120	220/127	240/138	
Series Delta (V)	240	254	277	240	254	277	
GNP 315 S	kVA	421	443	466	463	487	513
	kW	336	354	373	370	390	410
GNP 315 M	kVA	476	501	527	524	551	580
	kW	381	401	422	419	441	464
GNP 315 MX	kVA	490	516	543	539	568	597
	kW	392	413	434	431	454	478
GNP 315 MXA	kVA	528	556	585	581	612	644
	kW	422	445	468	465	490	515
GNP 315 L	kVA	580	611	643	638	672	707
	kW	464	489	514	510	538	566

REACTANCES (%) – TIME CONSTANTS (ms) : CLASS: H / 480 V

	480 V	315 S	315 M	315 MX	315 MXA	315 L
VOLTAGE SERIAL STAR						
DIR. AXIS SYNCHRONOUS	Xd	2,9925	2,8455	2,5725	2,5305	2,52
DIR. AXIS TRANSIENT	X'd	0,189	0,189	0,168	0,1617	0,1596
DIR. AXIS SUBTRANSIENT	X" d	0,1365	0,1365	0,126	0,12075	0,1155
QUAD. AXIS REACTANCE	Xq	2,52	2,4465	2,2575	2,226	2,205
QUAD. AXIS SUBTRANSIENT	X" q	0,378	0,336	0,294	0,2835	0,2625
LEAKAGE REACTANCE	XL	0,063	0,063	0,0525	0,0525	0,0525
NEGATIVE SEQUENCE	X2	0,252	0,231	0,2205	0,21	0,21
ZERO SEQUENCE	X0	0,0945	0,0945	0,08925	0,084	0,084
OTHER DATA – CLASS H / 400 V						
T'd TRANSIENT TIME CONST.		0,08 s	0,08 s	0,08 s	0,08 s	0,08 s
T'd SUB-TRANSTIME CONST.		0,019 s	0,019 s	0,019 s	0,019 s	0,019 s
T'do O.C. FIELD TIME CONST.		1,7 s	1,7 s	1,7 s	1,7 s	1,7 s
Ta ARMATURE TIME CONST.		0,018 s	0,018 s	0,018 s	0,018 s	0,018 s
SHORT CIRCUIT RATIO		1/Xd	1/Xd	1/Xd	1/Xd	1/Xd

315 SERIES

SYNCHRONOUS ALTERNATORS

4 POLE 50/60 Hz - THREE PHASE

GENPOWER[®]

ALTERNATOR

480V – 60 Hz

STANDARD SPECIFICATIONS

3 Phase / 480V / 60 Hz Efficiency Curves & Percent Transient Voltage Dip & Alternator Windings

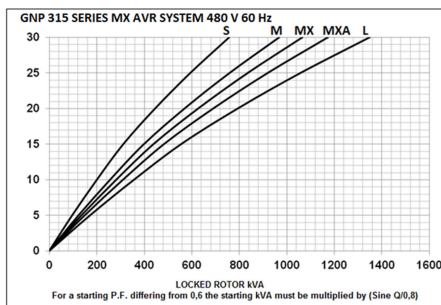
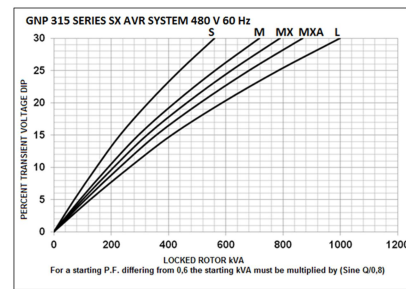
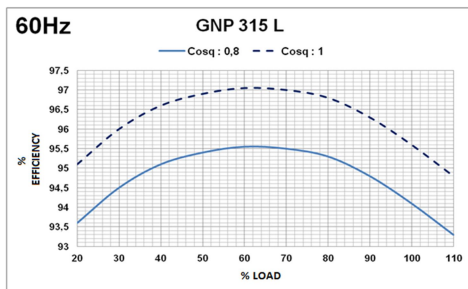
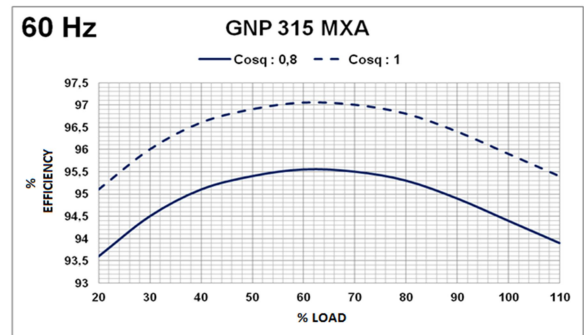
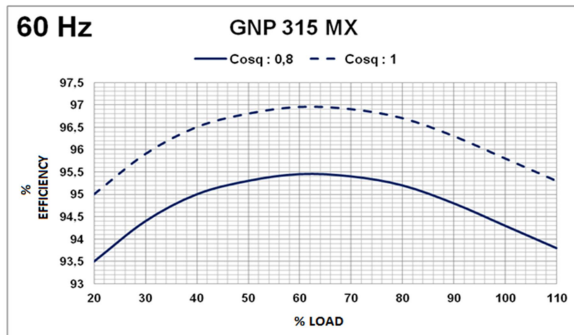
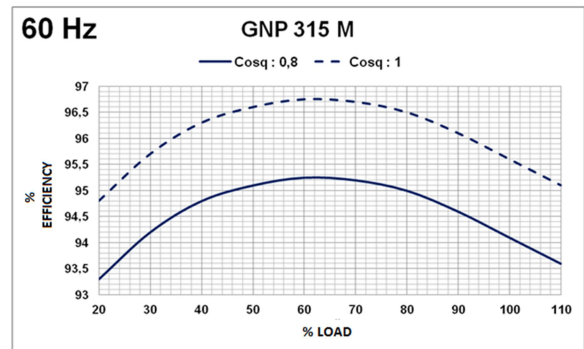
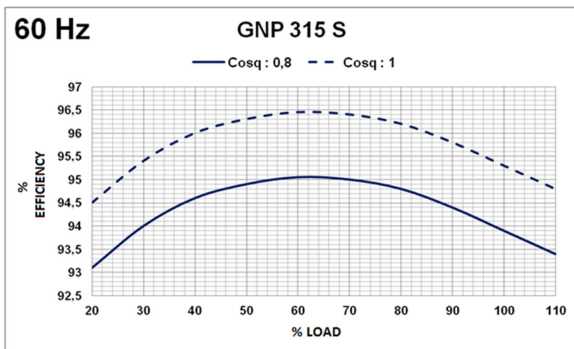

ALTERNATOR WINDINGS							
4 Pole	60 Hz - 1800 R.P.M						
Phase	3	3	3	3	3	1	1
Connections							
Number of Leads	6	6	12	12	12	12	12
Standard Winding	380 - 480V	220 - 277V	380 - 480V	220 - 277V	190 - 240V	220 - 240V	220 - 240V

TECHNICAL SPECIFICATIONS

High quality 100% copper wires are used in the rotors, stators and excitation wirings of GENPOWER alternators. All metal sheets used in the production are siliceous metals. Therefore, GNP alternators have higher efficiency compared to exemplary products.

315 SERIES

SYNCHRONOUS ALTERNATORS

4 POLE 50/60 Hz - THREE PHASE

GENPOWER®

ALTERNATOR

Dimensions

Dimensions

CONNECTION TYPE	SIZE						COUPLING DISC						
	SAE	MODEL	C-G	K	L	M	N	SAE	AN	AR	AS	AT	V
1	315 S		483	1175	1100	584	493	14	25,4	8	13,5	438,1	466,6
	315 M		504	1175	1100	584	493	FLANGE ADAPTER					
	315 MX-MXA		530	1265	1190	674	583	SAE	R	S	T	W	X
	315 L		530	1265	1190	674	583	1	12	12,7	530,2	511,1	553

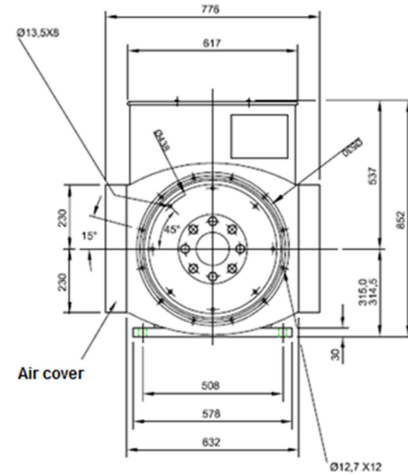
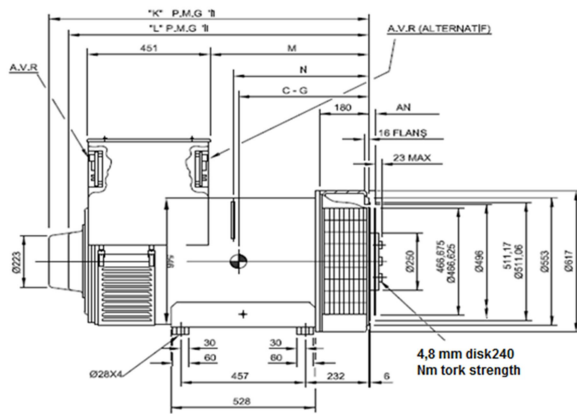

Special Products / Non - Standardized

Light Tower Alternators
Welding Alternators
High Frequency Alternators
Variable Speed Alternators

Direct Current Alternators - (DC)
Medium Voltage Alternators - (MV)
High Voltage Alternators - (HV)
IP44 and IP54 Class Alternators - (Marine)

Quality Documents & Certificates

Trademark Registration Certificate
Capacity Report (32400 Units / Year)
ISO 9001 - 2015 Certificate
ISO 14001 - 2015 Certificate
OHSAS 18001 - 2007 Certificate

Industrial Registry Certificate
Certificate of Manufacturing Competence
TSE - Service Adequacy Certificate
TS EN 60034 - 1 Certificate

TSE – Turkish Standards Institution Certificate
Certificate of Competency for After Sales Services
Made in Turkey Certificate- For Generator/ 1 - 5000 kVA



GENPOWER®

ALTERNATOR

Factory Address
ASO II. Industrial Zone
2010 Street No:18
06909 Temelli-Sincan/Ankara, Turkey
Tel/ Fax: +90(312) 641 32 22 - 641 32 32
info@genpower.com.tr
genpower@genpower.com.tr
www.genpower.com.tr