

# 400 SERIES

## SYNCHRONOUS ALTERNATORS

4 POLE 50/60 Hz - THREE PHASE

# GENPOWER®

ALTERNATOR

## General Information



STANDARD SPECIFICATIONS

TECHNICAL SPECIFICATIONS

### General Specifications

Genpower, is an independent and internationally recognized power producer, specializing exclusively on manufacturing of synchronous alternators.

Genpower focuses its corporate mission on original and self-made designs; innovative solutions and provide long-term and sustainable development.

Turkish and foreign technical teams are always working with their knowhow and experience in order to meet universal demands and projects and to have a continuous increase in the performance, total lifespan and overall reliability of the products. Genpower continues the R&D studies with universities both in Turkey and in other countries who have comprehensive knowledge on its products.

Genpower synchronous alternators are proven to endure the harshest environmental applications. They proved to be one of the most reliable and preferred alternator brands all over the world with their brushless and self-exciting system, electronic voltage regulator (AVR), stable wave form, low harmonic distortion and high efficiency.

In case of a demand, Genpower can also produce direct current (DC) alternators, 50-60 Hz low voltage (LV) alternators, medium voltage alternators, high voltage alternators; alternators for light towers, welding alternators, IP44 and PI54 class alternators for marine applications, variable speed alternators for telecom projects and cranes; high frequency alternators for ground power units, radars, planes and helicopters.

### Product Application

Genpower alternators are mainly used in the application of diesel, gasoline and gas generator groups. They are also able to operate with steam or hydraulic turbines. They operate in all configurations of emergency generator groups, power plants or continuous power sources.

- Industrial and commercial complex.
- Telecommunication and cell-phone towers, radio and television transmitters
- Defense industry and military projects.
- Construction sites, mining, stone crushers and mixing plants, light towers
- Agriculture and irrigation; cattle and chicken farms
- Hotels and hospitals, lofts, care centers, clinics
- Offices, shops, factories, workshops, buildings, sports complexes, stores, malls, banks, gas stations
- Rental companies, mobile service vehicles, mobile hospitals, and other mobile facilities
- Airports, initial starting of the air vehicles, ground services

### Standards

Genpower synchronous alternators are designed and manufactured in compliance with TSE 60034-1; IEC 60034-22; GB755; BS4999-5000; NEMA MG 1.22 CE marking approved and are also accredited with ISO 9001:2008 and ISO 14001:2004.

# 400 SERIES SYNCHRONOUS ALTERNATORS

4 POLE 50/60 Hz - THREE PHASE



## General Information

### Construction

Genpower alternators are made according to the requirements of the standard TSE 60034-1; IEC 60034-1. Using the best quality standards during manufacturing, the result is safe operation and great durability. Mounting styles normally supplied are; Single bearing with coupling by means of flanges and flexible disc. Double bearing with coupling by means of flange.

### Winding & Electrical Performance

All alternators stators windings are 2/3 pitch. This eliminates triple (3rd, 9th, 15th ...) harmonics on the voltage waveform and is found to be the optimum design for trouble-free supply of non-linear loads. The 2/3 pitch design avoids excessive neutral currents sometimes seen with higher winding pitches, when in parallel with the mains. A fully connected damper winding reduces oscillations during paralleling. This winding, with the 2/3 pitch and carefully selected pole and tooth designs, ensures very low waveform distortion.

High quality siliceous metals are used in the body and it increases the efficiency of the alternator.

### Excitation System & Automatic Voltage Regulators (AVR)

The self-warming control system supplies power from the main stator to the warning stator via AVR. The high efficiency semiconductors of AVR (diodes transmitters, etc.) allow the low permanent voltage to be positively raised. Three-phase excitation rotor diode bridge output supplies the main rotor excitation area. There is a varistor that protects the diode bridge and acts as a plug from shocks that may be short-circuited or similar.

With the Frequency / Voltage ratio (U / F) system, it protects AVR and alternator against low frequency.

It provides voltage adjustment opportunity within  $\pm 5\%$  limits for external voltage adjustment.

Automatic Voltage Regulators (AVR) are specially designed and catered for both single and parallel running operations for both self-excited and separately excited system (PMG).

STANDARD SPECIFICATIONS



MX 341 + PMG

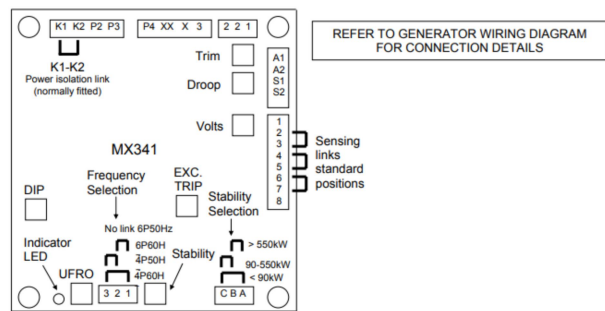

SUMMARY OF AVR CONTROLS		
CONTROL	FUNCTION	DIRECTION
Volts	To adjust generator output voltage	Clockwise increases output voltage
Stability	To prevent voltage hunting	Clockwise increase the damping effect
Ufro	To set the ufro knee point	Clockwise reduces the knee point frequency
Droop	To set the generator droop to 5% at 0pf	Clockwise increases the droop
Vtrim	To optimise analogue input sensitivity	Clockwise increases the gain or sensitivity
Exc trip	To set the over excitation cut off level	Clockwise increase the cut off level
Dip	To set the frequency related voltage dip	Clockwise increases the voltage dip

TECHNICAL SPECIFICATIONS

## General Information

### Terminal & Terminal Box

Standard generators are 3-phase reconnect able with 12 ends brought out to the terminals, which are mounted on a cover at the non-drive end of the generator. A sheet steel terminal box contains the AVR and provides ample space for the customers' wiring and gland arrangements. It has removable panels for easy access.

### Insulation / Impregnation (VPI)

The insulation system is class H. All winding components are impregnated in an unsaturated polyester resin of 200 class temperature. The impregnation provides much needed rigidity and protection against the harsh environment, typical for the generators applications. Genpower alternators are delivered with Genpower insulation system. This insulation system is based on the "Vacuum Pressure Impregnation" (VPI) system which was developed in cooperation with the most renowned suppliers of insulation material all over the world. Using special epoxy based resin; this insulation system ensures perfect winding insulation of the alternators and does not emit harmful gases into the environment.

### Dynamic Balancing

The rotating (Main rotor, exciter rotor, diode group, fan) parts are dynamically balanced with greater precision than that required by the Standard TSE EN IEC 60034-14 and ISO2372, ensuring minimum levels of residual unbalance.

### Waveforms / Radio Interference

The alternators are designed to give an excellent output waveform. The total harmonic content of line voltage waveform on no load is less than 5% as per limits specified by TSE / IEC Standards.

The Alternators are having negligible Radio Frequency Interference and meets the general limits permitted by VDE 0875 (N). TIF value is <50 and THF value is <2%.

### Transient Ratings

Transient voltage drop due to application of full load at 0.8 power factor is less than 18% output voltage recovers to within 3% of the rated value in less than 0.3 seconds.

### Continuous Duty / S1 – Ambient Temperature / 40°C

The alternator operates at rated power for an unlimited time with the possibility of overload up to 10% for 1 hour every 12 hours, without damage to its insulation system. The S1, also called continuous or prime duty is applied mainly where there is not another power source available, such as; groups for rental groups for irrigation, refrigeration and application for peak hours. For continuous duty, it is accepted a temperature raise in the windings of up to 125°C.

### Standby Duty – Ambient Temperature / 40°C

The generator group operates as energy backup with variable loads in emergency situations in places supplied by the grid / utility company or another main power source. In this kind of duty, the machine does not accept overloads and operates with variable loads up to the rated power of the stand-by duty (40°C). A raise in the winding temperature of up to 150°C is accepted (as per Standard of TSE 60034 / IEC 60034), However if that happens the useful life of the alternator reduces 2 to 6 times. The use of the alternator in stand-by duty is limited to 500 hours a year.

### Operating Conditions

When choosing an alternator, "ALTITUDE", "AMBIENT TEMPERATURE" and "POWER FACTOR" should be taken into consideration. Power drops should be calculated with the help of the table below and power determination should be done accordingly.

## General Information

### Altitude

The rated power refers to installations up to 1000 meter above sea level. For applications over this altitude, the following power correction factor must be applied.

Altitude (m)	<1000	<1500	<2000	<2500	<3000
K Factor	1	0.96	0.93	0.90	0.86

### Power Factor ( Cos Q)

The nominal power factor is 0.8 lagging. For application with power factor value different from 0.8, the following correction factor must be applied.

Power Factor (CosQ)	0.80	0.70	0.60	0.50	0.30	0
K Factor	1	0.93	0.88	0.84	0.82	0.80

### Temperature Rise

Temperature rise is the increase in temperature above ambient temperature 40°C ratings.

Temperature Rise	Temperature °C
B	80°C
F	105°C
H	125°C

### Generator Set Ratings

The tables below summarize the definitions accordance to TSE 8528-1 / ISO 8528-1 for the generator set and a combination of TSE 8528-3 / ISO 8528-3 and TSE 60034-1 / IEC 60034-1 for the alternator.

Genset Rating TSE 8528-1	Emergency Standby Power (ESP)	Limited Time Prime Power (LTP)	Prime Rated Power (PRP)	Continuous Operating Power (COP)
Load Type	Variable	Constant	Variable	Constant
Annual Operating Hours	200	500	Unlimited	Unlimited
Average Load	70%	100%	70%	100%
Overload	No	No	10% 1 Hour in every 12	No
Alternator Rating	Standby	Standby	Continuous	Continuous
Duty Cycle	S10	S10	S1	S1
Alternator Ratings	Standby 150/40°C	Standby 150/40°C	Class H 125/40°	Class H 125/40°
	Standby 163/27°C	Standby 163/27°C	Class F 105/40°C	Class F 105/40°C

### Ambient Temperature

The rated powers refer to installation with ambient temperature of 40°C. For applications different from 40°C, the following power correction factor must be applied.

Ambient Temperature	30°C	35°C	40°C	45°C	50°C	55°C
K Factor	1.04	1.02	1	0.96	0.93	0.90

### Thermal Insulation Class

Insulation class governs the maximum permissible temperature an alternator can operate without damaging the insulation system.

Insulation Class	Maximum Permissible Temperature
F	155°C
H	180°C

Stand-by application allows windings to run hotter than the class H temperature rise limit, therefore for an ambient of;

**40°C Temperature Rise : 150°C**

**27°C Temperature Rise : 163°C**

**400V – 50 Hz**

**Alternator Technical Data – 50Hz**

**4 POLE 1500 RPM 50 Hz**

**TYPICAL DATA**

Insulation class	H	Control system	Self excited
Winding pitch	2/3 - (N° 6)	A.V.R. model	MX 341 + PMG Standart
Wires	6	Voltage regulation	± 1.0 %
Drip proof	IP 23	Sustained short-circuit current	300% (3 IN) : 10s
Altitude	≤ 1000 m	Total harmonic (*) TGH / THC	< 4 %
Overspeed	2250 min -1	Wave form: NEMA = TIF - (*)	< 50
Air flow	1.614 m³/sec.	Wave form: I.E.C. = THF - (*)	< 2 %
Bearing drive	-	Bearing non-drive	6317 - 2RZ

(\*) Total harmonic content line to line, at no load or full rated linear and balanced load.

**50 Hz kVA / kW – Power Factor (CosQ) = 0,8**

Duty/Ambient C°	Continuous / 40°C			Stand-by / 27°C		
	H / 125° K			H / 163° K		
Class/C° rise						
Star (V)	380/220	400/231	415/240	380/220	400/231	415/240
Delta (V)	220	230	240	220	230	240
GNP 400 S	kVA	909	909	1000	1000	1037
	kW	727	727	800	800	830
GNP 400 M	kVA	1000	1000	1100	1100	1141
	kW	800	800	830	880	913
GNP 400 MX	kVA	1136	1136	1178	1250	1296
	kW	909	909	942	1000	1037
GNP 400 L	kVA	1273	1273	1321	1400	1453
	kW	1018	1018	1057	1120	1162
GNP 400 L1	kVA	1418	1418	1471	1560	1618
	kW	1134	1134	1177	1248	1294
GNP 400 L2	kVA	1500	1500	1556	1650	1712
	kW	1200	1200	1245	1320	1370
GNP 400 LX	kVA	1591	1591	1650	1750	1815
	kW	1273	1273	1320	1400	1452

**REACTANCES (%) – TIME CONSTANTS (ms) : CLASS: H / 400 V**

VOLTAGE SERIAL STAR	400 V	400 S	400 M	400 MX	400 L	400 L1	400 L2	400 LX
DIR. AXIS SYNCHRONOUS	X <sub>d</sub>	2,83	2,7	2,73	2,51	2,5	2,49	2,45
DIR. AXIS TRANSIENT	X' <sub>d</sub>	0,23	0,23	0,22	0,2	0,019	0,019	0,018
DIR. AXIS SUBTRANSIENT	X'' <sub>d</sub>	0,16	0,16	0,15	0,14	0,0133	0,013	0,012
QUAD. AXIS REACTANCE	X <sub>q</sub>	1,7	1,6	0,61	1,47	0,13965	0,13	0,12
QUAD. AXIS SUBTRANSIENT	X'' <sub>q</sub>	0,19	0,17	0,19	0,21	0,01995	0,02	0,02
LEAKAGE REACTANCE	X <sub>L</sub>	0,09	0,08	0,08	0,07	0,00665	0,007	0,006
NEGATIVE SEQUENCE	X <sub>2</sub>	0,2	1,18	0,19	0,2	0,019	0,019	0,018
ZERO SEQUENCE	X <sub>0</sub>	0,03	0,02	0,02	0,02	0,018	0,018	0,017
<b>OTHER DATA – CLASS H / 400 V</b>								
T' <sub>d</sub> TRANSIENT TIME CONST.		0,185	0,185	0,185	0,185	0,185	0,185	0,185
T'' <sub>d</sub> SUB-TRANSTIME CONST.		0,025	0,025	0,025	0,025	0,025	0,025	0,025
T' <sub>do</sub> O.C. FIELD TIME CONST.		2,35	2,44	3,03	3,4	3,4	3,5	3,5
T <sub>a</sub> ARMATURE TIME CONST.		0,04	0,04	0,046	0,049	0,05	0,05	0,48
SHORT CIRCUIT RATIO		1/X <sub>d</sub>	1/X <sub>d</sub>	1/X <sub>d</sub>	1/X <sub>d</sub>	1/X <sub>d</sub>	1/X <sub>d</sub>	1/X <sub>d</sub>

**400V – 50 Hz**

STANDARD SPECIFICATIONS

**3 Phase / 400V / 50 Hz Efficiency Curves & Percent Transient Voltage Dip & Alternator Windings**

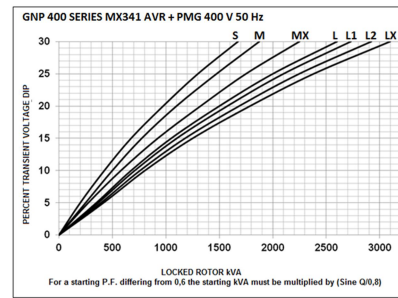
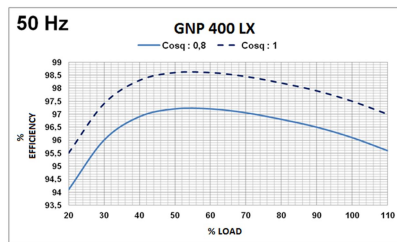
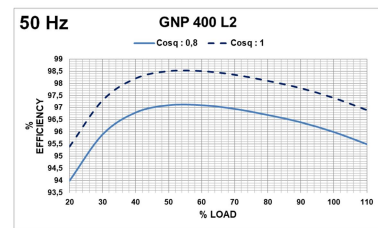
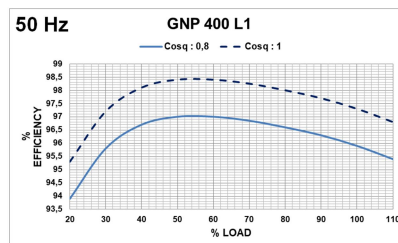
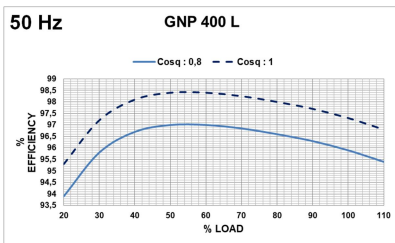
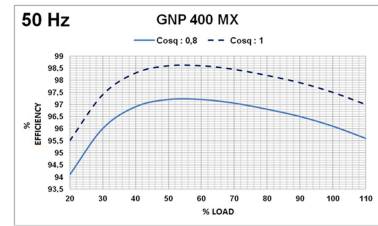
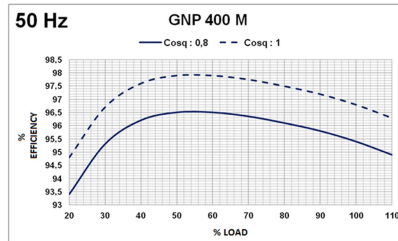
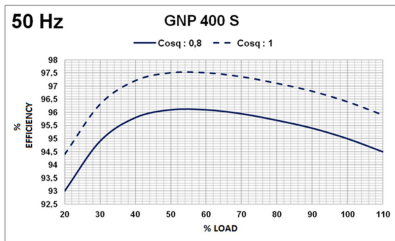

ALTERNATOR WINDINGS							
4 Pole							
50 Hz - 1500 R.P.M							
Phase	3	3	3	3	3	1	1
Connections							
Number of Leads	6	6	12	12	12	12	12
Standard Winding	380 - 400 - 415V	220 - 240V	380 - 400 - 415V	220 - 240V	190 - 208V	220 - 240V	220 - 240V

High quality 100% copper wires are used in the rotors, stators and excitation wirings of GENPOWER alternators. All metal sheets used in the production are siliceous metals. Therefore, GNP alternators have higher efficiency compared to exemplary products.

TECHNICAL SPECIFICATIONS

**480V – 60 Hz**

**Alternator Technical Data – 60Hz**

**4 POLE 1800 RPM 60 Hz**

**TYPICAL DATA**

Insulation class	H	Control system	Self excited
Winding pitch	2/3 - (N° 6)	A.V.R. model (*)	MX 341 + PMG Standard
Wires	6	Voltage regulation	± 1.0 %
Drip proof	IP 23	Sustained short-circuit current	300% (3 IN) : 10s
Altitude	≤ 1000 m	Total harmonic (**) TGH / THC	< 4 %
Overspeed	2250 min-1	Wave form: NEMA = TIF - (*)	< 50
Air flow	1.961 m³/sec.	Wave form: I.E.C. = THF - (*)	< 2 %
Bearing drive	-	Bearing non-drive	6317 - 2RZ

(\*) Total harmonic content line to line, at no load or full rated linear and balanced load.

**60 Hz kVA / kW – Power Factor (CosQ) = 0,8**

Duty/Ambient C°	Continuous / 40°C			Stand-by / 27°C			
	H / 125° K			H / 163° K			
Class/C° rise							
Star (V)	416/240	440/254	480/277	416/240	440/254	480/277	
Delta (V)	240	254	277	240	254	277	
GNP 400 S	kVA	1026	1080	1137	1129	1188	1251
	kW	821	864	910	903	950	1001
GNP 400 M	kVA	1129	1188	1250	1242	1307	1375
	kW	903	950	1000	994	1046	1100
GNP 400 MX	kVA	1283	1350	1421	1411	1485	1563
	kW	1026	1080	1137	1129	1188	1250
GNP 400 L	kVA	1435	1511	1591	1578	1662	1750
	kW	1148	1209	1273	1262	1329	1400
GNP 400 L1	kVA	1574	1657	1744	1731	1822	1918
	kW	1259	1326	1395	1385	1458	1534
GNP 400 L2	kVA	1639	1725	1816	1803	1898	1998
	kW	1311	1380	1453	1442	1518	1598
GNP 400 LX	kVA	1739	1830	1926	1913	2013	2119
	kW	1391	1464	1541	1530	1610	1695

**REACTANCES (%) – TIME CONSTANTS (ms) : CLASS: H / 480 V**

	480 V	400 S	400 M	400 MX	400 L	400 L1	400 L2	400 LX
VOLTAGE SERIAL STAR								
DIR. AXIS SYNCHRONOUS	Xd	2,9715	2,835	2,8665	2,6355	2,625	2,6145	2,5725
DIR. AXIS TRANSIENT	X'd	0,2415	0,2415	0,231	0,21	0,01995	0,01995	0,0189
DIR. AXIS SUBTRANSIENT	X''d	0,168	0,168	0,1575	0,147	0,013965	0,01365	0,0126
QUAD. AXIS REACTANCE	Xq	1,785	1,68	0,6405	1,5435	0,1466325	0,1365	0,126
QUAD. AXIS SUBTRANSIENT	X''q	0,1995	0,1785	0,1995	0,2205	0,0209475	0,021	0,021
LEAKAGE REACTANCE	XL	0,0945	0,084	0,084	0,0735	0,0069825	0,00735	0,0063
NEGATIVE SEQUENCE	X2	0,21	1,239	0,1995	0,21	0,01995	0,01995	0,0189
ZERO SEQUENCE	X0	0,0315	0,021	0,021	0,021	0,0189	0,0189	0,01785

**OTHER DATA – CLASS H / 480 V**

T'd TRANSIENT TIME CONST.	0,185	0,185	0,185	0,185	0,185	0,185	0,185	0,185
T''d SUB-TRANSTIME CONST.	0,025	0,025	0,025	0,025	0,025	0,025	0,025	0,025
T'do O.C. FIELD TIME CONST.	2,35	2,44	3,03	3,4	3,4	3,5	3,5	3,5
Ta ARMATURE TIME CONST.	0,04	0,04	0,046	0,049	0,05	0,05	0,05	0,48
SHORT CIRCUIT RATIO	1/Xd	1/Xd	1/Xd	1/Xd	1/Xd	1/Xd	1/Xd	1/Xd

# 400 SERIES SYNCHRONOUS ALTERNATORS

4 POLE 50/60 Hz - THREE PHASE

# GENPOWER<sup>®</sup> ALTERNATOR

## 480V – 60 Hz

STANDARD SPECIFICATIONS

### 3 Phase / 480V / 60 Hz Efficiency Curves & Percent Transient Voltage Dip & Alternator Windings

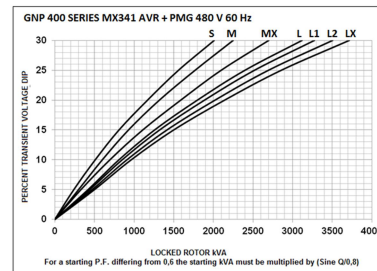
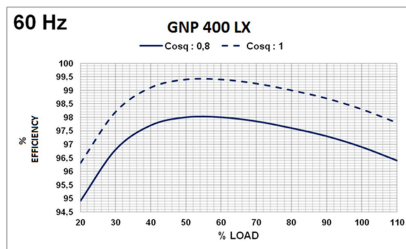
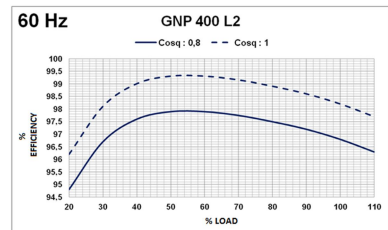
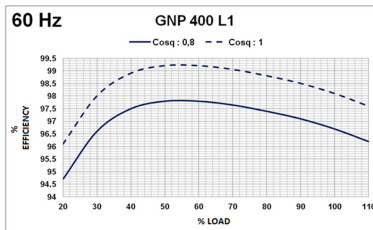
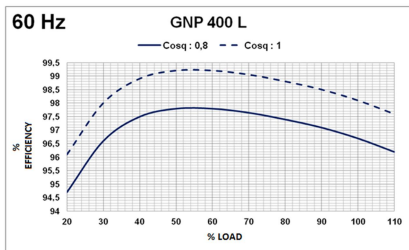
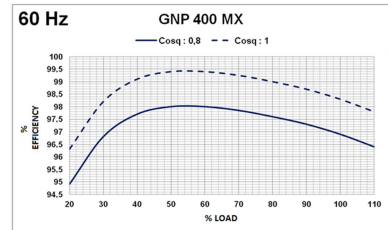
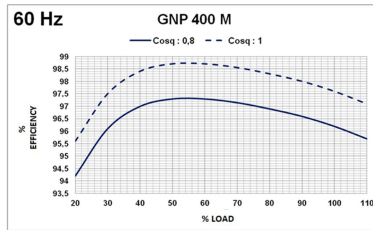
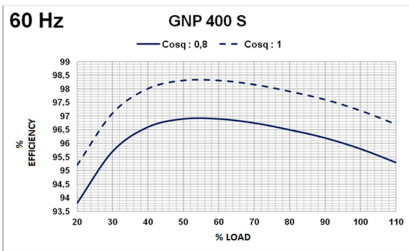

ALTERNATOR WINDINGS							
4 Pole							
60 Hz - 1800 R.P.M							
Phase	3	3	3	3	3	1	1
Connections							
Number of Leads	6	6	12	12	12	12	12
Standard Winding	380 - 480V	220 - 277V	380 - 480V	220 - 277V	190 - 240V	220 - 240V	220 - 240V

High quality 100% copper wires are used in the rotors, stators and excitation wirings of GENPOWER alternators. All metal sheets used in the production are siliceous metals. Therefore, GNP alternators have higher efficiency compared to exemplary products.

TECHNICAL SPECIFICATIONS

**400** SERIES  
**SYNCHRONOUS ALTERNATORS**  
 4 POLE 50/60 Hz - THREE PHASE

**GENPOWER**<sup>®</sup>  
 ALTERNATOR

**Dimensions**

**Dimensions**

**GNP 400 S-M-MX**

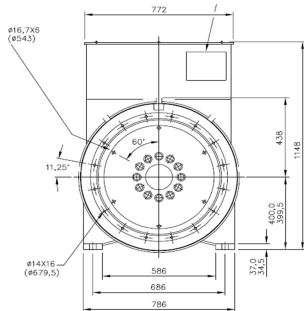
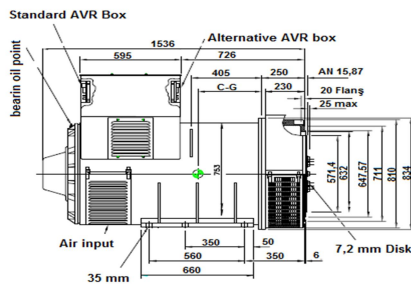

**GNP 400 L-L1-L2-LX**

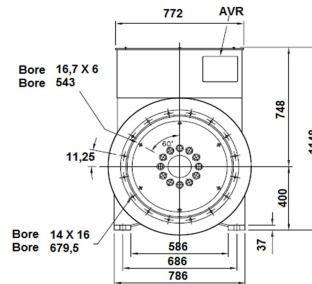
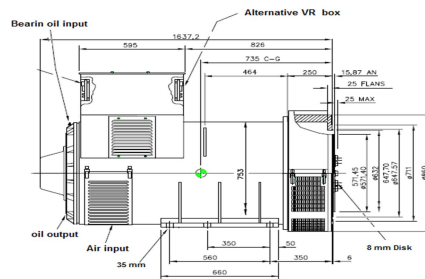

STANDARD SPECIFICATIONS

**Special Products / Non - Standardized**

- Light Tower Alternators
- Welding Alternators
- High Frequency Alternators
- Variable Speed Alternators

- Direct Current Alternators - (DC)
- Medium Voltage Alternators - (MV)
- High Voltage Alternators - (HV)
- IP44 and IP54 Class Alternators - (Marine)

**Quality Documents & Certificates**

- Trademark Registration Certificate
- Capacity Report (32400 Units / Year)
- ISO 9001 - 2015 Certificate
- ISO 14001 - 2015 Certificate
- OHSAS 18001 - 2007 Certificate

- Industrial Registry Certificate
- Certificate of Manufacturing Competence
- TSE - Service Adequacy Certificate
- TS EN 60034 - 1 Certificate

- TSE – Turkish Standards Institution Certificate
- Certificate of Competency for After Sales Services
- Made in Turkey Certificate- For Generator/ 1 - 5000 kVA



**GENPOWER**<sup>®</sup>  
 ALTERNATOR

**Factory Address**  
 ASO II. Industrial Zone  
 2010 Street No:18  
 06909 Temelli-Sincan/Ankara, Turkey  
 Tel/ Fax: +90(312) 641 32 22 - 641 32 32  
 info@genpower.com.tr  
 genpower@genpower.com.tr  
 www.genpower.com.tr

TECHNICAL SPECIFICATIONS



ISO 9001:2008  
 OHSAS 18001:2007  
 ISO 14001:2004



GENPOWER RESERVES THE RIGHT TO CHANGE THE CATALOGUES, PRODUCTS, MODELS AND TECHNICAL SPECIFICATIONS